

We have isolated [3,3] as the perchlorate salt by Ce(IV) oxidation of [2,2] in aqueous perchloric acid. For the [2,3] pentaammine dimer,  $(\text{NH}_3)_5\text{Ru}(\text{pyz})\text{Ru}(\text{NH}_3)_5^{5+}$ , Creutz and Taube<sup>1</sup> reported an intense band in the near-infrared spectrum and assigned it to charge transfer between metal ions  $[2,3] \rightarrow [3,2]^*$ . We have not been able to observe an analogous near-infrared band for the 2,2'-bipyridine [2,3] complex.

Only one oxidation wave is observed for the 4,4'-bipy and BPE bridged complexes ( $E_{1/2} = 0.84$  and  $0.82$  V, respectively) indicating that the ruthenium atoms are well shielded across the longer bridging ligands. Oxidation of the [2,2] ions at  $>1.0$  V gives  $n \sim 2$  (by

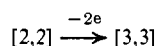

coulometry) showing that both rutheniums are oxidized to the +3 state. From the electrochemical measurements,  $K$  is 1 for the equilibrium

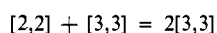

Equilibration among the three ions should be very rapid, because ruthenium polypyridine complexes are known to exchange electrons rapidly.<sup>7</sup> Therefore solutions containing [2,2], [2,3], and [3,3] can be prepared by partial oxidation of [2,2]. We are currently investigating the properties of the intermediate oxidation states of all three systems.

The 3:2 and 4:3 Ru-pyrazine bridged complexes,  $(\text{bipy})_2\text{ClRu}(\text{pyz})\text{Ru}(\text{bipy})_2\text{pyzRuCl}(\text{bipy})_2^{4+}$  [2,2,2] and  $(\text{bipy})_2\text{ClRu}(\text{pyz})\text{Ru}(\text{bipy})_2\text{pyzRu}(\text{bipy})_2\text{pyzRuCl}(\text{bipy})_2^{6+}$  [2,2,2,2], can also be oxidized. Two oxidation waves are observed for the 3:2 complex [ $E_p = 0.96$  V ( $n \sim 2$ ) and  $E_p = 1.05$  V ( $n \sim 1$ )] and three for the 4:3 complex ( $E_p = 0.96, 1.04, 1.17$  V). The oxidation waves apparently correspond to the reactions

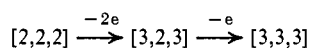

and

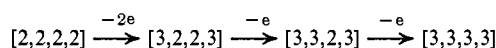

**Acknowledgments** are made to the University Research Council of the University of North Carolina and to the National Science Foundation (Grant No. GP17083) for support of this research and for a Science Development Award to the Department.

(7) J. C. Solenberger, Ph.D. Thesis, Washington University, St. Louis, Mo., June 1969.

(8) National Science Foundation Undergraduate Research Participant, summer, 1970.

S. Ajao Adeyemi, James N. Braddock, Gilbert M. Brown  
John A. Ferguson, Frank J. Miller,<sup>8</sup> Thomas J. Meyer\*

Department of Chemistry, University of North Carolina  
Chapel Hill, North Carolina 27514

Received September 29, 1971

## Bimolecular Homolytic Substitution with Inversion. A Stereochemical Investigation of an SH<sub>2</sub> Reaction

Sir:

Bimolecular homolytic substitution reactions (SH<sub>2</sub> reactions) represent one of the most common processes available to free radicals and, as a result, have been the subject of numerous investigations.<sup>1</sup> Few of these investigations, however, have dealt with the particular

(1) W. A. Pryor, *Chem. Eng. News*, **49**, 34 (June 7, 1971).

case of radical attack at saturated carbon; hence, the mechanistic scope of SH<sub>2</sub> attack at saturated carbon remains a subject of speculation.<sup>2</sup> With this background in mind, we have undertaken a mechanistic study of the bimolecular homolytic ring-opening reactions of cyclopropanes. The cyclopropanes represent a particularly informative compound series in that they have been extensively studied with regard to both electrophilic and nucleophilic attack.<sup>3</sup> It is our expectation that a comparison of our homolytic results with those obtained for the two polar modes of ring opening will prove to be of considerable theoretical interest.<sup>4</sup> In this communication we wish to report the results of studies which show that the ring-opening attack of chlorine atoms on 1,1-dichlorocyclopropane proceeds predominately with inversion of configuration.

When 1,1-dichlorocyclopropane is subjected to photochlorination at 0° in CCl<sub>4</sub>, two major products are obtained: 1,1,1,3-tetrachloropropane (**1**) and 1,1,1,3,3-pentachloropropane (**2**). A most logical sequence which may be postulated to explain these products is shown in Scheme I, and is the same as that proposed in-

Scheme I

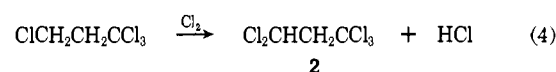
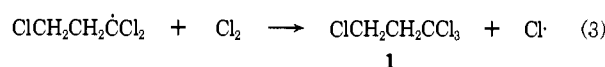
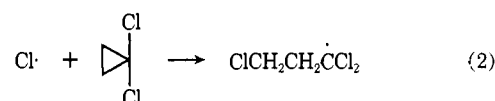

independently by Applequist, Fanta, and Hendrikson,<sup>5</sup> and Walling and Fredricks<sup>6</sup> for the photochlorination of various cyclopropane derivatives.

It was found that the chlorination of 1,1-dichlorocyclopropane is promoted by free-radical initiators and inhibited by free-radical scavengers. When 1-ml aliquots of a CCl<sub>4</sub> solution, 0.50 M in molecular chlorine and 3.14 M in 1,1-dichlorocyclopropane, were subjected to irradiation for 35 min at 0–5°, yields of **1** and **2** of 36 and 45%, respectively, were afforded.<sup>7</sup> In contrast, those aliquots<sup>8</sup> which were maintained in the dark at 0° for 24 hr afforded no detectable quantities of **1** or **2** (as determined by glpc analysis for **1** and **2**).<sup>9</sup> Similarly, those aliquots which were treated with 0.2 ml of HCl-saturated CCl<sub>4</sub> solution and subsequently maintained in the dark at 0° for 24 hr afforded no detectable quantities of **1** or **2** (glpc analysis). In the case of the "dark reactions," pmr analysis demonstrates that not less than 99% of the initially present 1,1-di-

(2) K. U. Ingold and B. P. Roberts, "Free Radical Substitution Reactions," Wiley, New York, N. Y., 1971, pp 5–6.

(3) S. J. Cristol, W. Y. Lim, and A. R. Dahn, *J. Amer. Chem. Soc.*, **92**, 4013 (1970), and references therein.

(4) J. A. Berson, *Angew. Chem., Int. Ed. Engl.*, **7**, 779 (1968).

(5) D. E. Applequist, G. F. Fanta, and B. W. Hendrikson, *J. Amer. Chem. Soc.*, **82**, 2368 (1960).

(6) C. Walling and P. S. Fredricks, *ibid.*, **84**, 3326 (1962).

(7) Irradiation was provided using a 150-W G.E. sunlamp.

(8) All of the aliquots referred to in this paragraph were taken from the same standard solution and were 0.50 M in molecular chlorine and 3.14 M in 1,1-dichlorocyclopropane.

(9) Using solutions prepared from authentic samples of **1** and **2** we have ascertained that yields of **1** or **2** as low as 1.5% would have been detected by glpc.

chlorocyclopropane remains intact. Finally, we observe that under irradiative conditions those aliquots to which benzoyl peroxide was added were accelerated, whereas those containing quinone were severely retarded (both modifiers were used at a concentration of about 2 mol % relative to  $\text{Cl}_2$ ). While these data do not of course, serve as a proof for Scheme I, they do provide convincing evidence for the free-radical chain nature of the chlorination process.

To elucidate the stereochemical consequences at the site of radical attack, we have prepared 1,1-dichloro-*cis*-2,3-dideuteriocyclopropane (**3**) and its *trans* analog **4**, and subjected both to photochlorination. As is summarized in Scheme II, different stereoisomers can

Scheme II

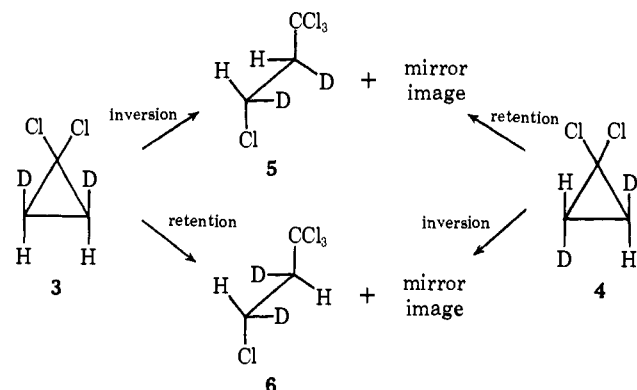

be obtained from **3** and **4** depending upon whether an inversion process or a retention process is operative.

The methods of Nicholas and Carroll<sup>10</sup> allowed for the ready preparation of *cis*- and *trans*-ethylene- $d_2$ , although as shown by infrared analysis, both olefins were contaminated with ethylene- $d_1$ . The quantity of this contaminant in the *trans*-ethylene- $d_2$  was determined by pmr analysis to be no greater than 15%. The syntheses of **3** and **4** were effected by the gas-phase reaction of trichloromethyltrifluorosilane with *cis*- and *trans*-ethylene- $d_2$ , respectively, in the presence of toluene; the nearly complete stereospecificity of these reactions was assumed in accord with the work of Fields, Haszeldine, and Peters.<sup>11</sup>

Our pmr results as obtained from a 250-MHz spectrometer are presented in Table I. A consideration

**Table I.** Photochlorinations of **3** and **4**. Assigned Products and Pmr Data

Starting material	Product $J_{AB}$ , Hz	Stereoisomer assigned	Peak positions, Hz from internal TMS
<b>3</b>	4.7	<b>5</b>	780.5, 785.3, 942.2, 946.9
<b>4</b>	11.2	<b>6</b>	778.5, 789.7, 940.5, 951.8

of conformer populations and the angular disposition of the hydrogen atoms in the most populated conformers allows us to assign the coupling constants of 4.7 and 11.2 Hz to the stereoisomers **5** and **6**, respectively.<sup>12</sup> To quantitatively assess our results a simplification of

(10) P. P. Nicholas and R. T. Carroll, *J. Org. Chem.*, **33**, 2345 (1968).

(11) R. Fields, R. N. Haszeldine, and D. Peters, *J. Chem. Soc. C*, 165 (1969).

(12) F. A. Bovey, "Nuclear Magnetic Resonance Spectroscopy," Academic Press, New York, N. Y., 1969, pp 132-141.

the pmr spectral patterns of **5** and **6** was required. This was accomplished by deuterium-hydrogen decoupling. The simplified spectra of **5** and **6** were sufficiently distinct so as to permit us to calculate an upper limit of 0.04 for the stereoisomeric product ratio, **5/6**, as obtained from the photochlorination of **4**. An upper limit of 0.035 was calculated for the ratio, **6/5**, as obtained from the photochlorination of **3**. From these results it is clear that the inversion process is the predominate if not exclusive mode of ring opening.

With regard to the more detailed aspects of the displacement process, our findings lead us to conclude that the sequences presented in Scheme III are in-

Scheme III

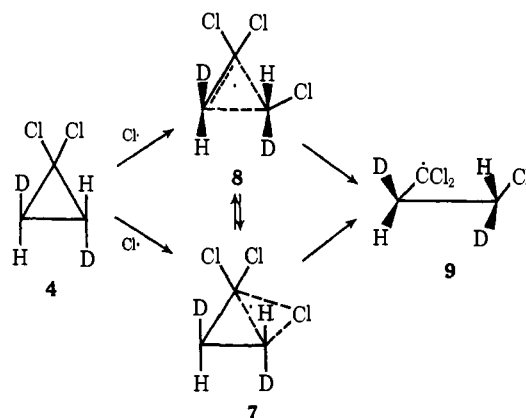

operative or, at best, are operative to a very limited degree. The edge-attached and corner-attached intermediates **7** and **8**, respectively, transform into an open-chain carbon-centered radical so as to effect a retention of configuration at the site of radical attack; a result which is, of course, contrary to our experimental findings. Similarly, we can essentially dismiss those one-step transformations of **4** to **9** where **7** or **8** function as transition states.

Our preferred explanation for the displacement is outlined in Scheme IV. This mechanism proposes a

Scheme IV

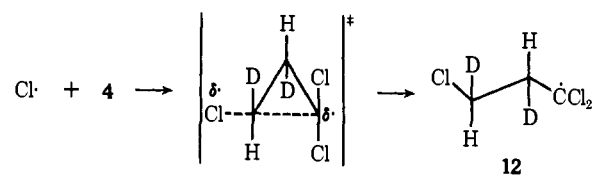

one-step displacement process, the transition state of which is somewhat geometrically similar to that normally envisioned for  $\text{S}_{\text{N}}2$  reactions. The bonding of the chlorine atom to a minor lobe of one carbon is envisioned as being concomitant with C-C bond cleavage and the incipient formation of the carbon-centered radical. Such a process affords inversion at the site of attack, and correctly predicts the direction of ring cleavage.<sup>13,14</sup>

Three other studies have provided conclusive evidence that radical attack on carbon can occur with inversion

(13) We have not detected any 1,2,2,3-tetrachloropropane in the product mixture obtained from the photochlorination of 1,1-dichlorocyclopropane.

(14) Our preferred mechanism is consistent with Scheme I in that displacement by  $\text{Cl}\cdot$  effects the formation of an open-chain carbon-centered radical. While step 2 of Scheme I is a most reasonable possibility, we cannot at this time provide evidence which refutes or supports the intermediacy of an open-chain free radical in the ring-opening process.

of configuration. These include: (a) the addition of bromine to 9,10-dehydrodianthracene,<sup>15</sup> (b) the addition of chlorine to nortricyclene,<sup>16</sup> and (c) the addition of bromotrichloromethane to dibenzotricyclo[3.3.0.0<sup>2,8</sup>]-3,6-octadiene.<sup>17</sup> Clearly, only the latter two investigations may be relevant with regard to the mechanism(s) of homolytic attack on cyclopropane and structurally simple cyclopropanes. The degree of relevance can be questioned since both nortricyclene and dibenzotricyclo[3.3.0.0<sup>2,8</sup>]-3,6-octadiene are tricyclic systems of considerable structural complexity. The importance of our study lies in the fact that 1,1-dichlorocyclopropane is a monocyclic system of relative structural simplicity and the only monocyclic system examined to date.

We propose, in view of the results obtained for 1,1-dichlorocyclopropane and the tricyclic systems, that the radical-induced ring opening of cyclopropanes will, for the majority of cases, occur preferentially *via* an inversion process. To confirm this proposal a greater variety of radical-cyclopropane systems will need to be examined. Our work in this area is continuing.

**Acknowledgments.** Our gratitude is expressed to Dr. Joseph Dadok of Mellon Institute for the spin-decoupling work and Drs. Jack Hausser and Kurt C. Schreiber for helpful discussions.

(15) D. E. Applequist and R. Searle, *J. Amer. Chem. Soc.*, **86**, 1389 (1964).

(16) M. L. Poutsma, *ibid.*, **87**, 4293 (1965).

(17) B. B. Jarvis, *J. Org. Chem.*, **35**, 924 (1970).

(18) NDEA Predoctoral Fellow, 1969-present.

Joseph H. Incremona,\* Charles J. Upton<sup>18</sup>  
Department of Chemistry, Duquesne University  
Pittsburgh, Pennsylvania 15219  
Received September 13, 1971

## Photochemical Behavior of Certain N-Substituted Diphenylaziridines. The Question of Isomerization vs. Fragmentation

*Sir:*

The photochemistry of phenylated epoxides has attracted considerable mechanistic and synthetic attention in recent years.<sup>1</sup> While it is agreed that electronic excitation of such substances leads for the most part to molecular fragmentation into a carbene and a ketone (or aldehyde) the mechanistic details of the fragmentation process have been the subject of considerable discussion and there appears to be disagreement as to whether these substances undergo C-C<sup>1,2</sup> or C-O<sup>3</sup> bond scission on excitation.<sup>4</sup> Presently we briefly describe our findings with certain select N-substituted 2,3-diphenylaziridines which, we believe, bear on this question and which provide some insight into the photochemical behavior of phenylated three-membered heterocycles in general. The three stereoisomeric pairs employed in the present study are shown in **1** and **2**.<sup>5</sup>

(1) P. C. Petrellis, H. Dietrich, E. Meyer, and G. W. Griffin, *J. Amer. Chem. Soc.*, **89**, 1967 (1969), and references listed therein.

(2) T. DoMinh, A. M. Trozzolo, and G. W. Griffin, *ibid.*, **92**, 1402 (1970).

(3) R. S. Becker, J. Kolc, R. O. Bost, H. Dietrich, P. Petrellis, and G. W. Griffin, *ibid.*, **90**, 3292 (1968); R. S. Becker, R. O. Bost, J. Kolc, N. R. Bertoni, R. L. Smith, and G. W. Griffin, *ibid.*, **92**, 1302 (1970).

(4) For a timely and comprehensive review of the subject, see: G. W. Griffin, *Angew. Chem., Int. Ed. Engl.*, **537** (1971).

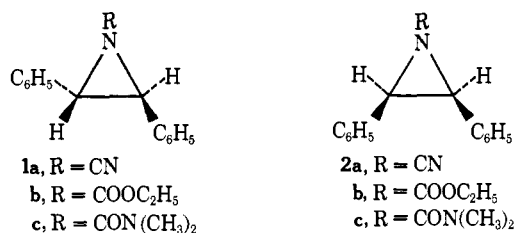

In the case of the **1a,2a** pair,<sup>6</sup> irradiation at 2537 Å (quartz optics) in solution and at ambient temperature leads not to fragmentation but rather to clean isomerization, the results of a few representative runs being detailed in Scheme I.<sup>7</sup> It is thus seen that while both

Scheme I

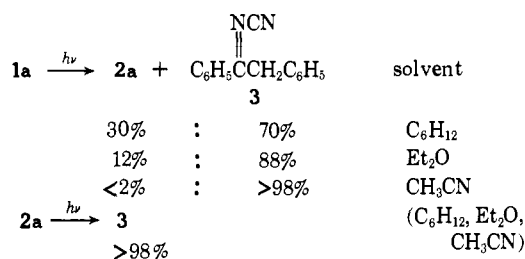

stereoisomers rearrange to **3**<sup>8</sup> on illumination only the trans isomer undergoes detectable stereoisomerization to the cis counterpart under the same conditions.<sup>9</sup> Further, the product distribution in the photolysis of **1a** appears to exhibit strong solvent dependence whereby the proportion of **3** in the photolysate invariably increases with enhanced solvent polarity.

Under similar photolysis conditions the stereoisomeric urethanes **1b** and **2b**<sup>10</sup> undergo clean geo-

(5) The compounds shown in **1** were prepared on treatment of *trans*-2,3-diphenylaziridine (A. Weissberger and H. Bach, *Chem. Ber.*, **64**, 1095 (1931)) with either cyanogen bromide, ethyl chloroformate, or *N,N*-dimethylcarbamoyl chloride while those depicted in **2** were synthesized on treatment of *cis*-2,3-diphenylaziridine (K. Kotera, S. Miyazaki, H. Takahashi, T. Okada, and K. Kitahonoki, *Tetrahedron*, **24**, 3681 (1968)) with the same reagents.

(6) **1a** showed: mp 81–82°;  $\nu_{\text{CN}}^{\text{KBr}}$  2180 cm<sup>-1</sup>;  $\lambda_{\text{max}}$  (C<sub>6</sub>H<sub>12</sub>) 271 (ε 545), 265 (868), 258 nm (885); nmr (CDCl<sub>3</sub>) τ 2.60 (10 H, singlet), 6.05 (2 H, singlet). **2a** showed: mp 115–116°;  $\nu_{\text{CN}}^{\text{KBr}}$  2190 cm<sup>-1</sup>;  $\lambda_{\text{max}}$  (C<sub>6</sub>H<sub>12</sub>) 270 (sh) (ε 228), 264 (423), 259 (476), 253 nm (402); nmr (CDCl<sub>3</sub>) τ 2.85 (10 H, singlet), 5.72 (2 H, singlet). In addition, these substances gave correct elemental analyses.

(7) Each tabulated run is one of several conducted by varying the irradiation time from 5 to 30 min. Brief irradiation proved necessary in order to prevent photodecomposition of **3** which sets in on longer exposure to light. The amount of unreacted aziridine contained in the mixtures listed in Scheme I ranged from 65 to 80%. In each case the photolysate was analyzed immediately, by nmr, employing both CDCl<sub>3</sub> and benzene-*d*<sub>6</sub> as solvents.

(8) Alkylidene cyanamide **3** was characterized on the basis of its nmr (CDCl<sub>3</sub>) spectrum (τ 1.9–2.2 (2 H, multiplet), 2.5–2.8 (8 H, multiplet), and 5.52 (2 H, singlet)) and through its ready conversion to deoxybenzoin on treatment with moist alumina.

(9) It was pointed out by a referee that the implication that **1a** can form **3** as a primary photoproduct, without going through **2a**, is not demanded by the information collected in Scheme I. While we cannot categorically state that **3** materializes directly from **1a** we draw attention to the fact that **2a** photolyzes exclusively to **3** under the same conditions. When viewed in light of the fact that (a) the photostationary state in the case of the **1b-2b** and **1c-2c** pairs consists of **2** (cis) and **1** (trans) in a ratio of ca. 9:1 (*vide infra*) and (b) the steady-state concentration of **2a** (cis) in the photolysis of **1a** (trans) amounts to only ca. 8% of the total mixture (**1a** + **2a** + **3**), this observation is, we believe, best accommodated by a scheme whereby initially formed **1a** is drained irreversibly into **3** at a steady-state concentration which is much too low (<1%) for detection by nmr spectroscopy.

(10) **1b** showed: mp 56–57°;  $\nu_{\text{CO}}^{\text{KBr}}$  1710 cm<sup>-1</sup>;  $\lambda_{\text{max}}$  (C<sub>6</sub>H<sub>12</sub>) 273 (ε 427), 266 (807), 260 nm (955); nmr (CDCl<sub>3</sub>) τ 2.66 (10 H, singlet), 6.02 (2 H, quartet), 6.23 (2 H, singlet), 9.50 (3 H, triplet). **2b** showed: mp 54–55°;  $\nu_{\text{CO}}^{\text{KBr}}$  1715 cm<sup>-1</sup>;  $\lambda_{\text{max}}$  (C<sub>6</sub>H<sub>12</sub>) 270 (sh) (ε 234), 265 (390), 260 (466), 253 nm (392); nmr (CDCl<sub>3</sub>) τ 2.87 (10 H, singlet), 5.78 (2 H, quartet), 6.08 (2 H, singlet), 8.73 (3 H, triplet). In addition, these substances gave correct elemental analyses.